

# Y-TYPE STRAINERS

## MODELS & SPECIFICATIONS



### Y150/300/600CS

Carbon Steel

### Y150/300/600SS

Stainless Steel

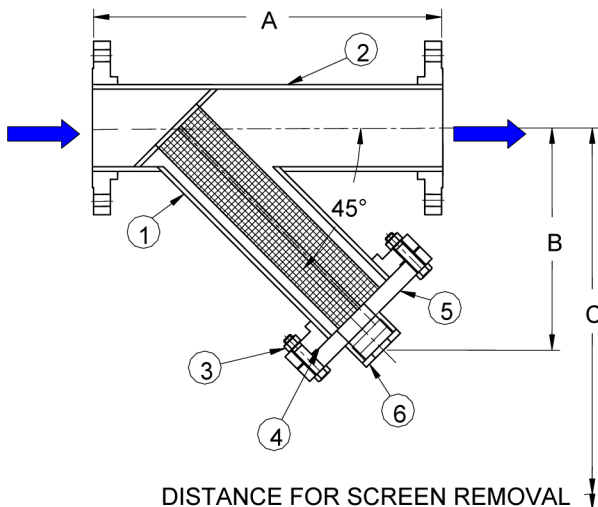

## FEATURES

*I F T* fabricated “Y” strainers are designed and fabricated to ASME Section VIII and/or applicable ANSI codes. Standard size ranges are, but not limited to, 1-1/2” to 24” with 150#, 300# and 600# ANSI ratings with the capability to supply units with 900#, 1500# and 2500# ratings. Screen and body sizes can be tailored to suit any pressure drop or space requirements the customer might have. Standard materials of construction are carbon and stainless steel, however *I F T* can and does fabricate “Y” strainers to meet your requirements from almost any alloy. The strainer may be installed in horizontal or vertical pipelines with blow-off connection at lower end of screen.

## BILL OF MATERIALS

Item	Description	Qty
1	SCREEN	1
2	BODY	1
3	NUTS AND BOLTS	as req.
4	GASKET	1
5	COVER FLANGES	1
6	DRAIN PLUG	1

## STANDARD SCREENS

Size	Opening	Std. Mesh/Perf.
1-1/2”-24”	0.125”	1/8” perf.

Other perforations and basket materials available.

## OPTIONS

- Flanged, butt weld, grooved inlet/outlet connections available.
- Automatic/manual flush
- Hinged/Clamp quick release cover assemblies (see pages 36 & 37)
- Full range of NDE/NDT testing
- Special coatings

**NOTES:** SPECIFICATION AND SIZES CAN CHANGE WITHOUT PRIOR NOTICE; FOR REFERENCE ONLY; NOT TO BE USED FOR PRE-PIPING WORK; NOT TO SCALE  
ACCURATE DIMENSIONS AND DETAILS WILL BE ISSUED WITH ENGINEERING DRAWING



385 Watline Avenue, Mississauga, Ontario, L4Z 1P3